

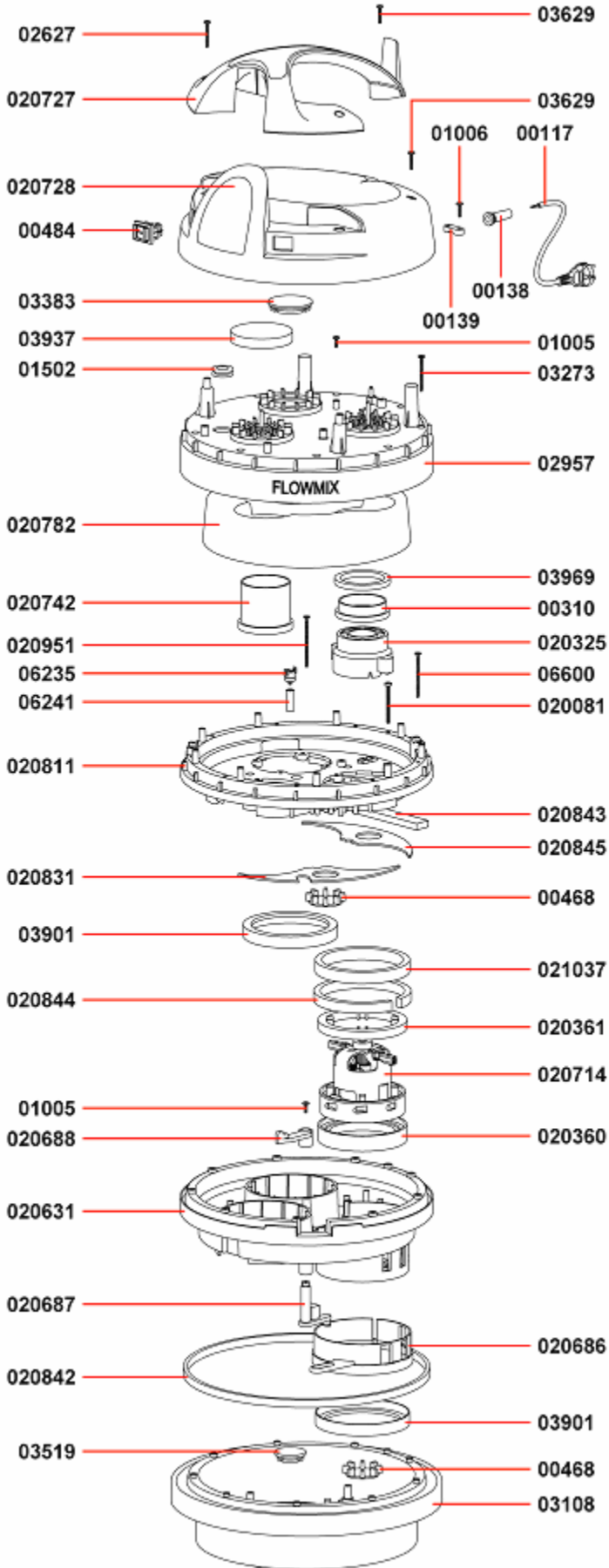

TOPPER HEAD 429 F-M W/PLA GREEN/G6

021031 P VEI G6



Codice	Descrizione	N°
00117	ELECTRIC CORD 2X1 MT.8,5	1,00
00138	FAIRLEAD	1,00
00139	CABLE CLAMP	1,00
00310	PLASTIC RING FOR MOTOR H=15	1,00
00468	AUTOMATIC VALVE	3,00
00468	AUTOMATIC VALVE	2,00
00484	ANTISPLASH RED LIGHT SWITCHER	2,00
01005	SCREW PAT TMT PHL 5X14 ZN BLACK	2,00
01005	SCREW PAT TMT PHL 5X14 ZN BLACK	1,00
01006	SCREW PFU TMT PHL 5X20 BLACK	1,00
01502	GUIDING SLIT FOR QUICK COUPLING	1,00
020081	CROSS SCREW TC M 5X60 UNI 7687	1,00
020325 AU	COVER/ADAPTER F/MOT.BYPASS SELF-EXT	2,00
020360	"L" GASKET D.130 H=13	2,00
020361	"C" GASKET D.130	2,00
020631G6	MOT.FASTENER FLOW MIX 2 MOTORS G6	1,00
020686	GATE VALVE	1,00
020687	LEVER FOR GATE VALVE	1,00
020688	LINKAGE FOR GATE VALVE	1,00
020714	MOT.BS282 CP 1000W 220-240 50/60 M	2,00
020727VEI	TOPPER HANDLE 600 IPC-GREEN	1,00
020728G6 2I	TOPPER COVER 600 G6 2 SWITCHES	1,00
020742	SPACER FOR SERIES AND PARALLEL H.70	1,00
020782	ANTI-NOISE 400/600 D320X65	1,00
020811G6	MOT.FASTENER HS 600 GREY 6000	1,00
020831	MUFFLER DEVICE ON LEVER SIDE	1,00
020842	GASKET 6X12 DIA 380	1,00
020843	ANTI-NOISE 140X25X10	3,00
020844	ANTI-NOISE 440X15X10	1,00
020845	MUFFLER DEVICE	2,00
020951	CROSS SCREW TS 5X80	1,00
021037	FOAM FILTER S-EXT.146X126X18 PPI45	1,00
02627	SCREW PAT TMT PHL 5X40 BLACK	2,00
02957VEI	NEV.600 COVERING-IPC GREEN	1,00
03108 PVEI	BASE 600/400 W/PLATE IPC-GREEN COMP	1,00
03273	SCREW PAT TMT PHL 5X55 BLACK	9,00
03383	COVERING CAP	1,00
03519	BASE CAP	1,00
03629	SCREW PAT TMT PHL 5X25 BLACK	1,00
03629	SCREW PAT TMT PHL 5X25 BLACK	2,00
03901	"L" GASKET W/O HOLES H=5,5	2,00
03901	"L" GASKET W/O HOLES H=5,5	1,00
03937	FILTER MTP/65 H=15 D.95	2,00
03969	WASHER H8 D85X65	2,00
06235	THERMOREGULATOR MAX T.85 C	1,00
06241	THERM. PROBE	1,00
06600	CROSS SCREW TS 5X70	12,00
07632 L TP	CONNECTION 50CM TP MOTOR	2,00
07976 2MOT	ELECTR.KIT 600 TP 2MOT RAD	1,00



COMPL.FILTRATION KIT 400 CONICAL

04246

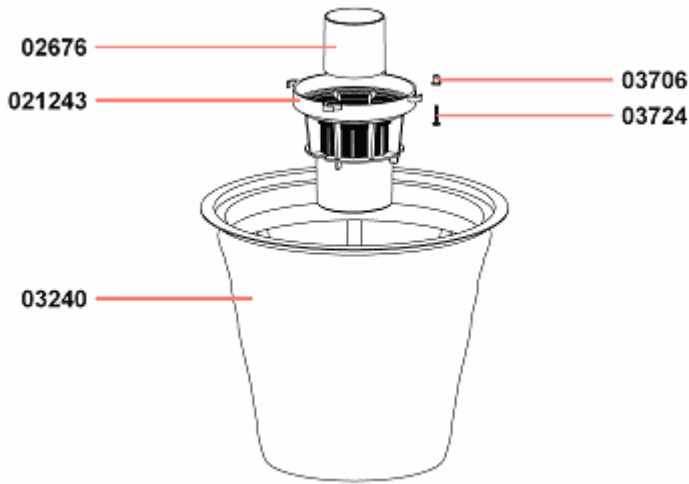

Codice	Descrizione	N°
021243NE	NET ANTIFOAM BODY HIGH	1,00
02676-1 G	HIGH FLOAT 99 W/GASKET 37 SHA	1,00
03240 SAN	KIT RING+FILT+BASK.400 CONIC.SAN	1,00
03706	PLASTIC SLEEVE D.8	4,00
03724	SCREW PAT TMT PHL 5X25	4,00

TANK 400M A430 R G6GREE/G6/G6 DRAIN

020968 G6 VEI

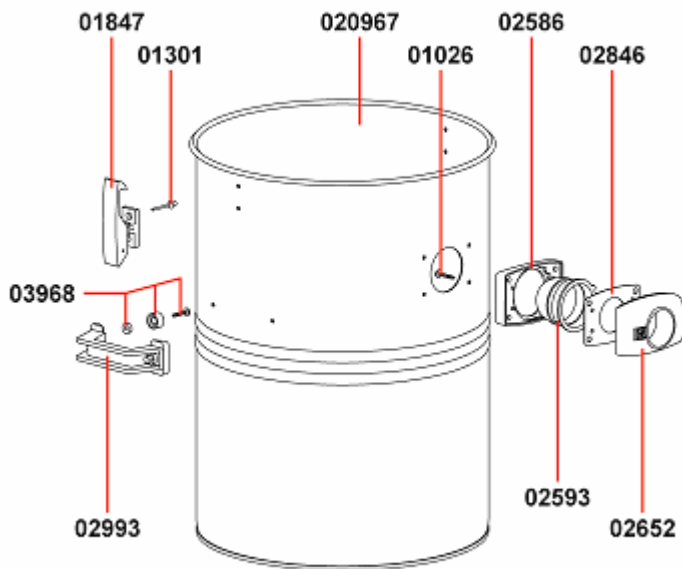

Codice	Descrizione	N°
01026	SCREW PAT TMT PHL 5X30 BLACK	4,00
01301	RIVET 5X11	4,00
01847/SG6	COMPLETE PLASTIC HOOK GREY6000	2,00
020967 C/R SCA	TANK 400 AISI C/R WITH DRAIN HOSE	1,00
02586G6	GASKET R 205 GREY 6000	1,00
02593	DEFLECTOR 99	1,00
02652 AG6VE-IPC	INLET R155 G6000 W/IPC GREEN BUTTON	1,00
02846	GASKET D.38	1,00
02993-1G6	GREY 6000 HANDLE	2,00
03968	COMPLETE SEAL W/SCREW L=25	4,00

DRAIN DEVICE D.34 COMP.MARK

02994/MARK

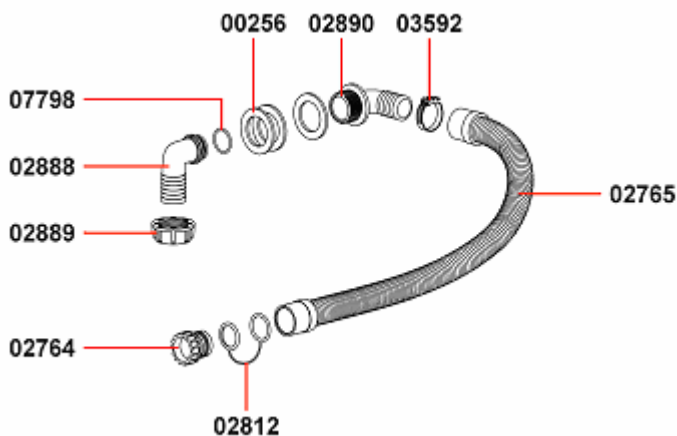

Codice	Descrizione	N°
00256	GASKET 60X40X4	3,00
02764/C	PLASTIC CAP D.40 X 35 W/OR COMPL.	1,00
02765	DRAIN TUBE D.34 L=600	1,00
02812	TIE ROD CAP	1,00
02888	RUBBER HOLDER UNION	1,00
02889	PULLEY 1-1/4"	1,00
02890	RUBBER HOLDER UNION CURVED 90°1-1/4	1,00
03592	CLIP 300X9	1,00
07798	OR 28 X 2,5 NBR	1,00



BASE MARKET TROLLEY FOR DRAIN

00900 BASE/SCA

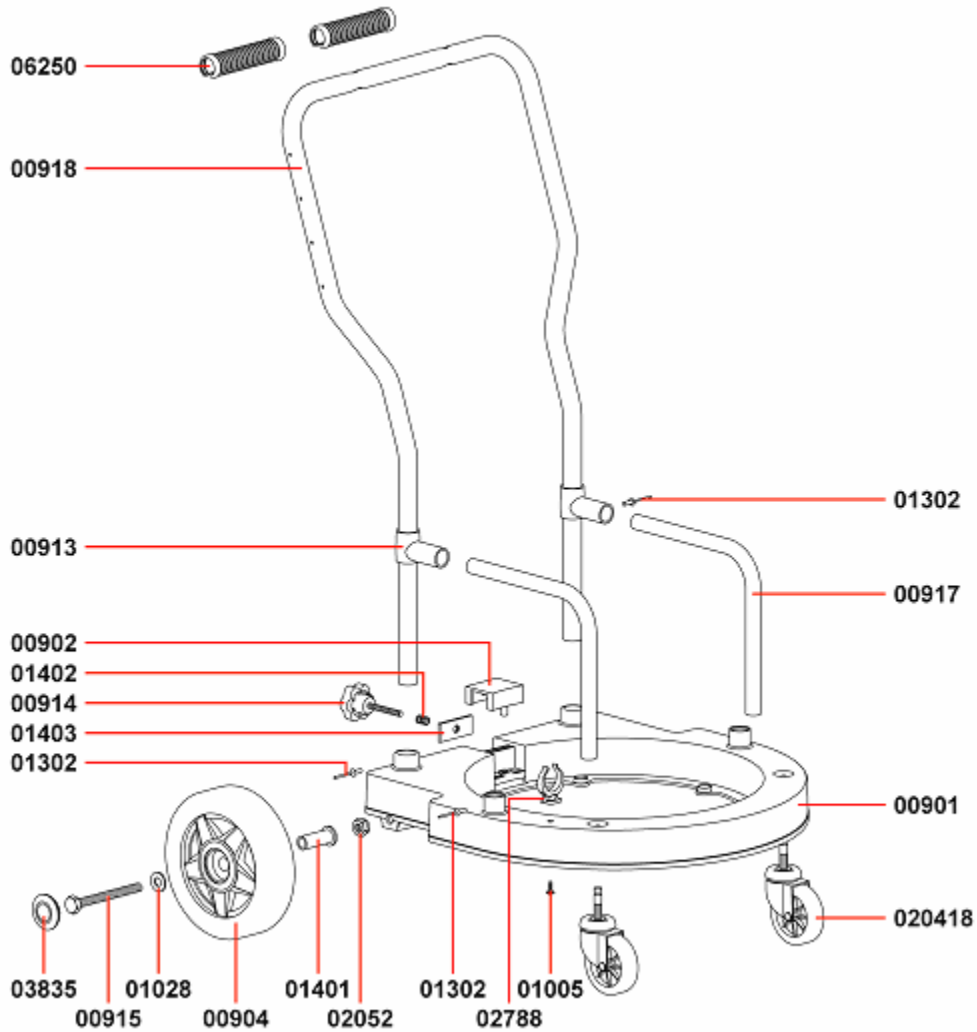

Codice	Descrizione	N°
00901NE-1	BODY TROLLEY MARKET BLACK	1,00
00902	SMALL BLOCK	1,00
00904	REAR WHEEL D.200	2,00
00913	"T" TUBE	2,00
00914	HAND-WHEEL M 8X60	1,00
00915	SCREW "TE" M 12X140 UNI 5737 8G	2,00
00917 V	VARNISHED SUPPORT TUBE	2,00
00918-1 V	MARKET HANDLE 400 BLACK VARN.	1,00
01005	SCREW PAT TMT PHL 5X14 ZN BLACK	1,00
01028	WASHER M12 UNI 6592	2,00
01302NE	RIVET 5X15 BLACK	2,00
01302NE	RIVET 5X15 BLACK	2,00
01302NE	RIVET 5X15 BLACK	2,00
01401	BUSH FOR REAR WHEEL	2,00
01402	SPIRAL SPRING FOR SMALL BLOCK L16MM	1,00
01403	LOCKING THREADED PLATE	1,00
020418	FRONT WHEEL D.80 W/PIVOT	2,00
02052	SELFLOCKING NUT M 12 LOW	2,00
02788	LIRA CLAMP D.34	1,00
03835NE	WHEEL CAP D.200/250 BLACK	2,00
06250	PLAST.TROLLEY HANDLE	2,00